

## EN-51: The User Defined Sensor

- Each analogue input channel of a Vykon HVAC module can be configured to one of a number of analogue sensor types. The firmware of the module contains some pre-programmed lookup tables that represent popular sensors which are described in engineering note EN20. By using these sensor types the configuration process is simplified because the lookup table does not need entering and in operation, the I/O module returns a real value from the sensor thereby eliminating any conversion processing within the station runtime.
- If, however, you are not able to use any of these pre-programmed popular sensor types, the “User defined” option is available on every Analogue Input channel so that you can create a conversion look-up table to support your particular sensor. This engineering note describes how to configure a ‘User defined’ sensor type.

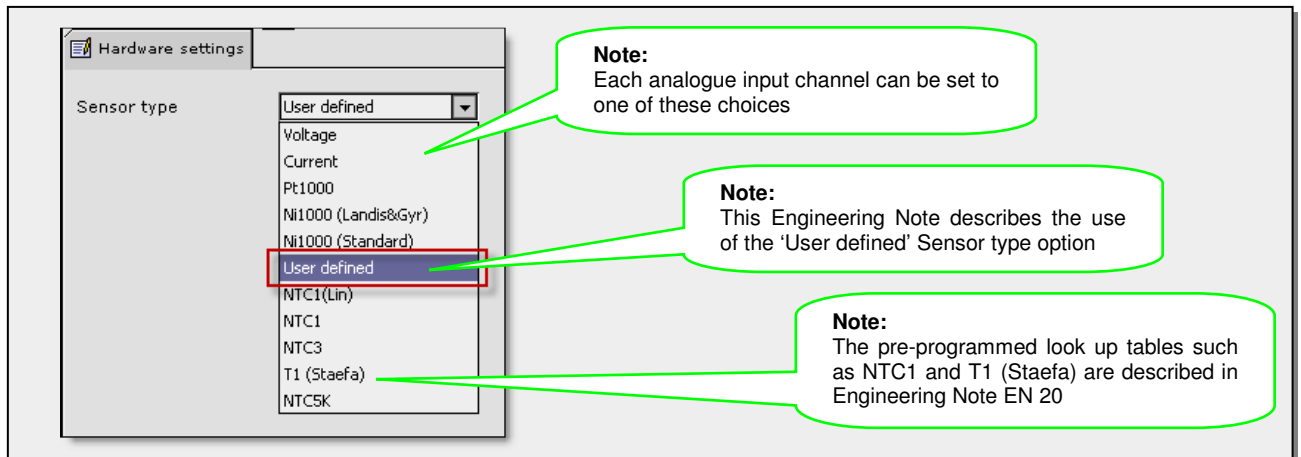

- In this example an RTD (resistance temperature detector) sensor is being used which is not supported by any of the module’s internal lookup tables. The sensor is a Honeywell NTC20K and it is connected to the analogue input channel of channel 2 of the 8-AI module. All the other channels of this module are similar as well as the Analogue Input channels on the MULTI-I/O module.

- As an overview to the operation, the 'Sensor type' of the channel must be set to "User defined" and the module's internal pull up resistor ( $R_t$ ) must be retained in circuit. In this example, because the sensor is a 10k device, the factory fitted pull up resistor  $R_t$ , of  $40,000\Omega$  is retained in order to minimise the sensor's self-heating effect by reducing the power applied to the sensor. A  $5,110\Omega$  resistor (provided bagged in the carton) can alternatively be used for other, lower resistance RTD sensors. (Note that Vykon HVAC modules with a software version less than v9.00 have a factory fitted pull up resistor  $R_t$  of  $5,110\Omega$  and this can be replaced with  $40,000\Omega$  if required)
- The subsequent voltage produced by the sensor, after signal conditioning, is read by the module's Analogue to Digital converter and the voltage value is converted to a temperature by a lookup table within the Vykon HVAC module proxy point. A lookup table must be created and it will be based upon the RTD sensor's "temperature-to- resistance" characteristic. The "Volt" voltage will determine the appropriate temperature "Value".

### Equivalent circuit

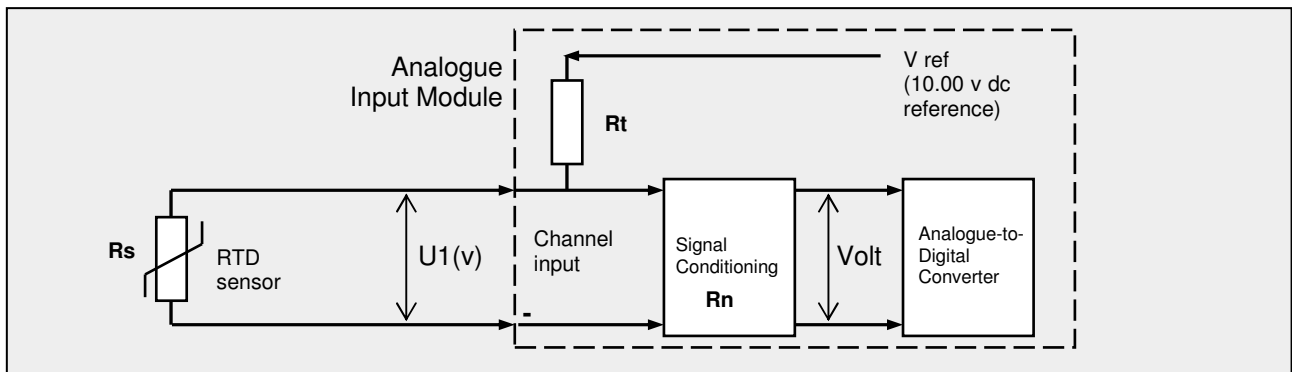

**Module and Sensor characteristic**

**Retain Rt**

channel  
1 2 3 4

**Tip:**  
The reference voltage of the analogue input channel may be checked at these top connections. It is 10.00vdc

From the published 'temperature/resistance table, create a workbook to calculate the voltage of A-D input at the various temperatures

Honeywell NTC20K

Temperature is detected by an NTC20 thermistor sensor with a nominal resistance of 20 kohm / 25°C. The pocket is installed to the water pipe by means of threads R1/2".

Temperature/Resistance:

°C	NTC 20 / Ω	°C	NTC 20 / Ω
120	609	25	20000
100	1114	20	25350
90	1541	15	32346
80	2166	10	41567
75	2585	5	53812
70	3099	0	70203
65	3732	-5	92322
60	4517	-10	122431
55	5494	-15	163777
50	6718	-20	221088
45	8259	-25	301297
40	10211	-30	414698
35	12698	-40	810861
30	15887	-50	1659082

**Tip:**  
Calculate the voltage 'Volt' using the formulae:  
$$\text{Volt} = ((R_s * R_n) / ((R_s * R_n) + ((R_s + R_n) * R_t))) * V_{ref}$$

$$A11 = ((C11 * B5) / ((C11 * B5) + ((C11 + B5) * B5))) * B4$$

	A	B	C	D	E
1	<b>Honeywell NTC20K</b>				
2	Type:	Thermistor			
3	Used by:	Honeywell			
4	Vref (volt)	10			
5	Rt (ohm)	40,000			
6	Rn (ohm)	204,800			
7	<b>Honeywell NTC20K</b>				
8	<b>Advanced Tab</b>				
9	Volt	Value °C	Rs Ω		
10	<b>Sensor Characteristic</b>				
11	8.20	-50	1659082		
12	8.13	-45	1152992		
13	8.03	-40	810861		
	7.91	-35	576763		
	7.74	-30	414698		
		-25	301297		
		-20	221088		
		-15	163777		

## Channel properties

Select the User defined sensor type on the relevant input channel

Select a number of co-ordinates for your lookup table

**Tip:** You will need to 'Save' the Sensor type before you can see this entry

Enter the Volt and Value into the 'Advanced settings' tab of the channel

**Warning:** Ensure that the 'Volt' series increments through the incrementing coordinate entries: (1:0.15v, 2:0.20v, 3:0.27v... etc)

**Tip:** Select Volt and Value co-ordinates appropriately to match your required temperature range

Advanced Tab			
	Volt	Value °C	Rs Ω
<b>Sensor Characteristic</b>			
11	8.20	-50	1659082
12	8.13	-45	1152992
13	8.03	-40	810861
14	7.91	-35	576763
15	7.74	-30	414698
16	7.53	-25	301297
17	7.27	-20	221088
18	6.95	-15	163777
19	6.57	-10	122431
20	6.14	-5	92322
21	5.67	0	70203
22	5.16	5	53812
23	4.63	10	41567
24	4.11	15	32346
25	3.61	20	25350
26	3.51	21	24164
27	3.41	22	23039
28	3.32	23	21973
29	3.22	24	20962

	Volt	Value		Volt	Value		Volt	Value		Volt	Value			
1:	0.15 V	120.0		6:	0.71 V	70.0		11:	2.30 V	35.0		16:	4.63 V	10.0
2:	0.20 V	110.0		7:	0.99 V	60.0		12:	2.69 V	30.0		17:	5.67 V	0.0
3:	0.27 V	100.0		8:	1.40 V	50.0		13:	3.13 V	25.0		18:	6.57 V	-10.0
4:	0.37 V	90.0		9:	1.66 V	45.0		14:	3.61 V	20.0		19:	7.27 V	-20.0
5:	0.51 V	80.0		10:	1.96 V	40.0		15:	4.11 V	15.0		20:	7.74 V	-30.0

**A couple of 'User Defined' sensors**

Here are sample lookup tables for the Honeywell NTC20K sensor and the Sontay 3K3A1 sensor:

Honeywell NTC20K		
Advanced Tab		
Volt	Value 'C	Rs Ω
Sensor Characteristic		
8.20	-50	1659082
8.13	-45	1152992
8.03	-40	810861
7.91	-35	576763
7.74	-30	414698
7.53	-25	301297
7.27	-20	221088
6.95	-15	163777
6.57	-10	122431
6.14	-5	92322
5.67	0	70203
5.16	5	53812
4.63	10	41567
4.11	15	32346
3.61	20	25350
3.51	21	24164
3.41	22	23039
3.32	23	21973
3.22	24	20962
3.13	25	20000
3.04	26	19092
2.95	27	18228
2.86	28	17407
2.78	29	16628
2.69	30	15887
2.30	35	12698
1.96	40	10211
1.66	45	8259
1.40	50	6718
1.18	55	5494
0.99	60	4517
0.84	65	3732
0.71	70	3099
0.60	75	2585
0.51	80	2166
0.43	85	1823
0.37	90	1541
0.31	95	1307
0.27	100	1114
0.20	110	818
0.15	120	609
0.11	130	459
0.09	140	351

Sontay 3K3A1		
Advanced Tab		
Volt	Value 'C	Rs Ω
Sensor Characteristic		
7.17	-50	200348
6.28	-40	100701
5.13	-30	53005
3.89	-20	29092
3.31	-15	21868
2.77	-10	16589
2.30	-5	12694
1.89	0	9795
1.82	1	9309
1.75	2	8850
1.68	3	8416
1.62	4	8006
1.55	5	7619
1.27	10	5971
1.03	15	4714
0.84	20	3748
0.81	21	3583
0.78	22	3426
0.75	23	3277
0.72	24	3135
0.69	25	3000
0.66	26	2871
0.64	27	2749
0.61	28	2633
0.59	29	2522
0.56	30	2417
0.46	35	1959
0.38	40	1598
0.32	45	1310
0.26	50	1080
0.22	55	895.5
0.18	60	746.2
0.15	65	624.7
0.13	70	525.5
0.11	75	444
0.09	80	376.9
0.08	85	321.2
0.07	90	274.8
0.06	95	236.1
0.05	100	203.6
0.04	110	153
0.03	120	116.6
0.02	140	70.23

**Tip:**  
The 'Green' values are a **suggested** selection for the 20 entries in the 'Advanced settings' tab of the channel property sheet. You should choose the quantity of coordinates and the series that best suits your application

